

TORROT 

**A BRAND TO DISCOVER**  
UNA MARCA POR DESCUBRIR

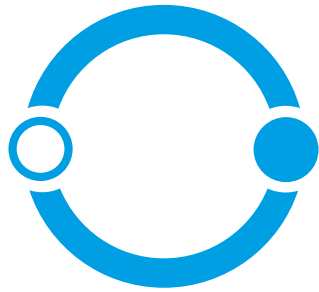



PERSONAL MOBILITY  
INTERCONNECTED



KIDS  
SCHOOL

*Legend*  
TT series

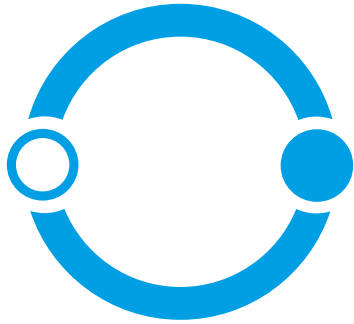

## PERSONAL MOBILITY INTERCONNECTED

### SIGHTEDNESS

**personal mobility interconnected**, this range includes our electric bicycles and e-scooters, among other vehicles that Torrot will design, manufacture and market. The future of personal mobility is linked to the connection between vehicles. Therefore Torrot connects your vehicle with the user and the city, getting an efficient, safe and sustainable Smart city and positioned as personal mobility interconnected provider of next-generation electric vehicles.

### VISIÓN DE FUTURO

**Personal mobility interconnected**, esta gama incluye nuestras bicicletas y scooters eléctricos, entre otros vehículos que Torrot está diseñado y construyendo. El futuro de la movilidad personal va ligado a la conexión entre vehículos, Por ello Torrot conecta sus vehículos con el usuario y la ciudad, consiguiendo una Smart city eficiente, segura y sostenible, posicionándose así como proveedor de movilidad personal interconectada de vehículos eléctricos de nueva generación.

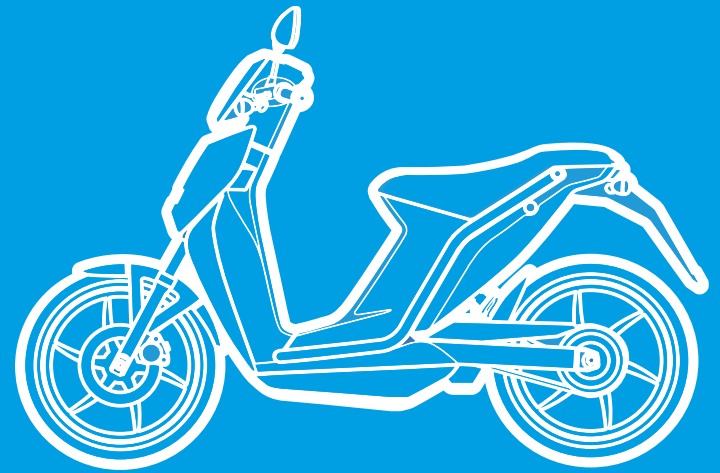

MUVI



# MUVi



PERSONAL MOBILITY  
INTERCONNECTED







## COLOUR OPTIONS

### OPCIONES DE COLOR



WHITE PIRINEO  
BLANCO PIRINEO



EXECUTIVE BLACK  
NEGRO EJECUTIVO



CLOUDY GREY  
GRIS CLOUDY

The first lightweight electrical scooter designed to move you around with no hassles. It's super-easy to drive, comfortable, has a small boot for a jet or demi-jet helmet and comes with LED lights in front and back, disk brakes and everything you are looking for to move you around the city in a fun, safe, efficient way. Its informal, extroverted aesthetic was designed for people like you who value time and practicality above all else.

El primer scooter eléctrico lightweight diseñado para moverte de aquí a allá sin complicaciones: es muy fácil de conducir, cómoda, cuenta con un pequeño maletero para un casco jet o demijet, y va provista de luces led de día delante y detrás, frenos de disco y todo aquello que buscas para moverte por tu ciudad con seguridad, diversión y eficiencia. Su estética informal y extrovertida ha sido pensada para personas como tú, que valoras el tiempo y el practicismo por encima de todo.



## BATTERY PACK PACK DE BATERÍAS

### CHARGE ITS BATTERIES WHEREVER YOU WANT

The Muvi has removable batteries which you can easily recharge anywhere. Charge them in just four hours wherever and however you want: in the garage, at the office or at public charging points. Plus, depending on your needs, the Muvi can be configured to fit you: choose it with more or less power depending on how you're going to use it.

### CARGA SUS BATERÍAS DONDE QUIERAS

Muvi tiene baterías extraíbles que puedes cargar en cualquier parte muy fácilmente. Cárgalas donde y con como quieras, en el garaje, o la oficina, o en los puntos de carga públicos en tan solo 4 horas. Además, y en función de tus necesidades, Muvi es configurable para adaptarse a tí: elígela con más o menos potencia



# CONNECTIVITY AND CONTROL

## CONECTIVIDAD Y CONTROL



### SMARTPHONE APP

Control and configure your MUVI with your Android or iOS smartphone. Turn your MUVI into a social and interactive vehicle.

### APP PARA SMARTPHONE

Controla y configura tu MUVI con tu smartphone Android o iOS y conviértela en un vehículo interactivo y social.

# ECU + DISPLAY TORROT BP-1



**DASHBOARD1**



**DASHBOARD2**



**DASHBOARD3**

LCD Display 4" 320 x240

CAN BUS communication + bluetooth

Remote diagnosis APP Smartphone / Tablet + diagnosis OBD-1

Direct communication with Torrot through GPRS APP Smartphone

Management of consumption patterns (1/2 batteries, temperatures, remaining range)

Allows keyless ignition system.

The user can select between three different dashboard screens designs through APP

Display LCD 4" 320 x240

Comunicaciones via CAN BUS+ bluetooth

Diagnosis remota via APP Smartphone / Tablet + diagnosis OBD-1

Permite comunicación directa con Torrot, via datos GPRS APP Smartphone

Gestión de los modos de consumo (1/2 baterias, temperaturas, autonomía restante)

Permite sistema Keyless de encendido.

El usuario puede elegir entre tres configuraciones de display mediante la APP

# TECHNICAL SPECIFICATIONS

## ESPECIFICACIONES TÉCNICAS

FRAME / CHASIS	TUBULAR STEEL FRAME / TUBULAR DE ACERO
FRONT SUSPENSIÓN / SUSP. DELANTERA	HYDRAULIC TELESCOPIC FORK / HORQUILLA TELESCOPICA HIDRÁULICA
REAR SUSPENSIÓN / SUSP. TRASERA	SIDE MONOSHOCK WITH PRELOAD ADJUSTMENT/ MONOAMORTIGUADOR LATERAL CON AJUSTE EN PRECARGA
BRAKES / FRENOS	HYDRAULIC COMBINED BRAKE SYSTEM (CBS) 220mm FRONT-190mm REAR/ SISTEMA FRENADA COMBINADA HIDRAULICA 220mm DEL. - 190mm TRAS. )
TRANSMISSION / TRANSMISIÓN	TOOTHED BELT HTD 1:5,6 / CORREA DENTADA HTD 1:5,6
ENGINE / MOTOR	TORROT BRUSHLESS 48V
POWER / POTENCIA	4,1CV (3 Kw) / 35 Nm
MAX SPEED/ VELOCIDAD MAX.	(CITY) 45KM/H (EXECUTIVE) 60KM/H
BATTERY / BATERÍA	REMOVABLE 2x48V 25Ah LINiCoMn RANGE UP TO 110km / EXTRAIBLES 2x48V 25Ah LINiCoMn HASTA 110KM DE AUTONOMIA
DIAGNOSTICS - COMMUNICATIONS / DIAGNOSIS - COMUNICACIONES	ECU (Electronic Control Unit) CAN-BUS / BLUETOOTH
DASHBOARD	INTELLIGENT, LCD 4" 320x240 CUSTOMIZABLE VIA APP (iOS / Android)
RIMS / LLANTAS	ALUMINIUM 16" x2.15/ ALUMINIO 16" x2.15
TIRES / NEUMATICOS	90/80-16
WEIGHT / PESO	85KG BATTERIES INCLUDED / 85 KG BATERIAS INCLUIDAS
CHARGER / CARGADOR	54.6V 5A DOUBLE BATTERY CHARGER (5HOURS) / 54.6V 5A CARGADOR DOBLE (5HORAS)
OPTIONAL / OPCIONAL	54.6V 10A DOUBLE BATTERY CHARGER (2,5HOURS) / 54.6V 10A CARGADOR DOBLE (2,5HORAS)

**MUVI**  
EXECUTIVE

"125cc" (L3e)

**MUVI**  
CITY

Moped bike / ciclomotor (L1e)

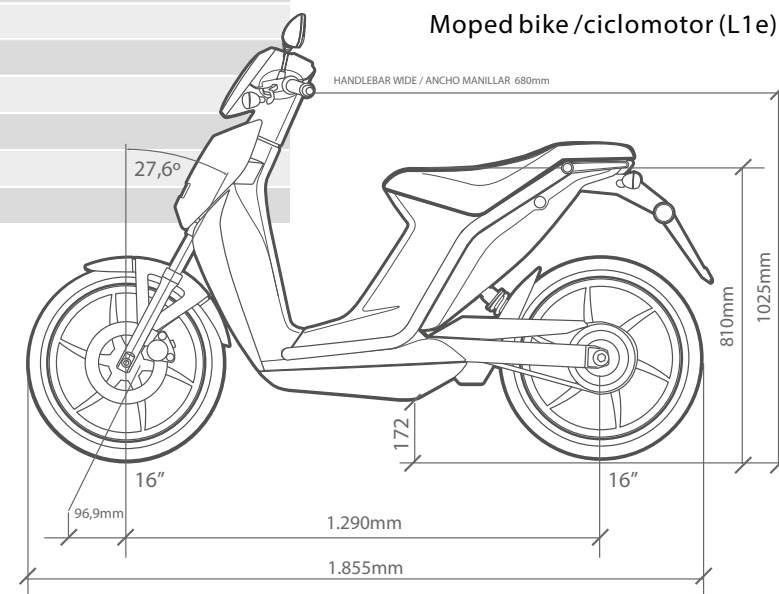

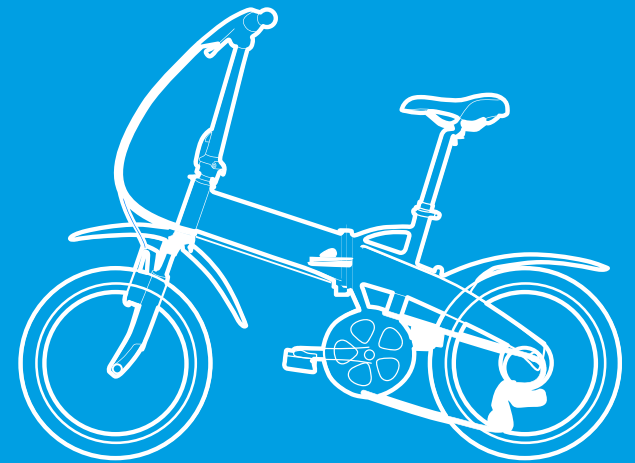

CITY  
SURFER











PERSONAL MOBILITY  
INTERCONNECTED





# CITY SURFER

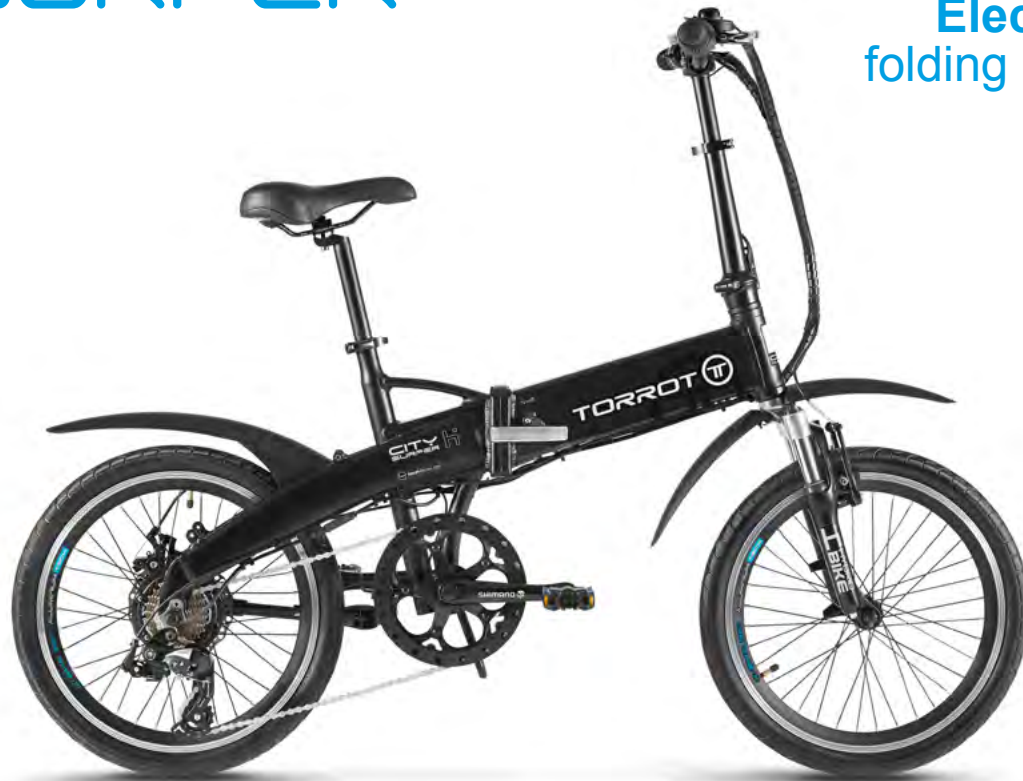

Electric  
folding bike 



The Citysurfer is a small, foldable, lightweight bicycle with an aluminium alloy chassis. It is unusually nimble and powerful, with a 6-speed Shimano TX gear shift and a seat designed for extra comfort. This urban bike has been designed for practical, original people to literally "surf" the city.

La Citysurfer es pequeña, plegable, ligera con su chasis en aleación de aluminio, muy ágil y potente como pocas, con cambio Shimano TX de 6 velocidades y un sillín especial para una comodidad extra. Esta Urban Bike ha sido diseñada para "surfear" literalmente por la ciudad, para gente práctica y original.



PERSONAL MOBILITY  
INTERCONNECTED







# TECHNICAL SPECIFICATIONS

## ESPECIFICACIONES TÉCNICAS

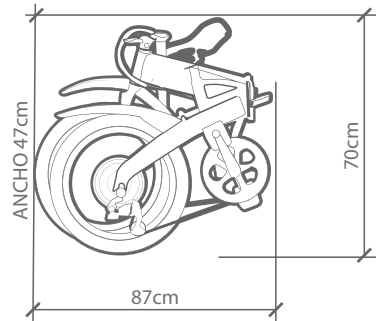
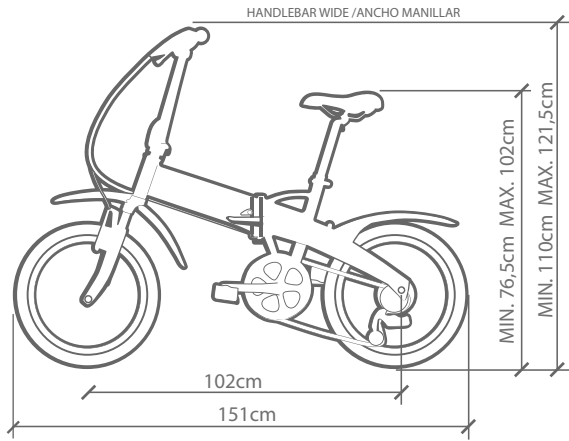

FRAME / CUADRO	GIRDER ALUMINIUM ALLOY 6061 / MONOVIGA EN ALEACIÓN DE ALUMINIO 6061
FORK / HORQUILLA	RST ALUMINIUM-STEEL / RST ALUMINIO-ACERO
GEAR / CAMBIO	SHIMANO TOURNEY TX35
BRAKES / FRENO	V-BRAKE FRONT + REAR NOVEL DISC / V-BRAKE DELANTE + DISCO NOVELA DETRÁS
TRANSMISSION / TRANSMISIÓN	SHIMANO TX 6 SPEED PEDALIER SINGLE PAN / SHIMANO TX 6 VELOCIDADES, PEDALIER MONOPLATO
ENGINE / MOTOR	BRUSHLESS GEARED 36V / 250W
SEAT - SHANK / SILLÍN-TIJA	VELO COMFORT SEAT AND ALUMINIUM SHANK / SILLÍN CONFORT VELO, TIJA EN ALUMINIO
TIRES/ NEUMATICOS	MIXTO KENDA 1.75/20" FRONT - REAR / DEL. - TRAS.
RIMS / LLANTAS	ALUMINIUM 20" DOUBLE WALL FRONT-REAR / ALUMINIO DOBLE PARED 20" DEL. - TRAS.
BATTERY / BATERÍA	LI-ION 36V 10,44 AH CELDAS SAMSUNG + BMS DIGITAL
ASSISTED MAXIMUM SPEED / VEL. MAX. ASISTIDA	25 Km/h
WEIGHT / PESO	19 KG (BATTERY INCLUDED) / 19KG (BATERIA INCLUIDA)
OTHERS / VARIOS	BATTERY CHARGER INCLUDED. DESIGNED AND ASSEMBLED IN SPAIN CARGADOR BATERÍA Y CABLES INCLUIDOS. DISEÑADA Y ENSAMBLADA EN ESPAÑA
OPTIONAL ACCESSORIES / ACCESORIOS OPCIONALES	LUGGAGE STORAGE 12KG TO 22KG./MAX. BETTERY WITH CHARGER. CHILD CARRIER. PORTAPAQUETES DE 12KG A 22KG./MAX. BATERIA CON CARGADOR. SILLA PORTA NIÑOS.



### **FOR YOUNG RIDERS**

KIDS, are the electric motorcycle series for young riders. For very fast off-road learning and advancement nothing compares to these mini-endurocross bikes.

### **PARA JÓVENES PILOTOS**

La serie de motocicletas KIDS para jóvenes pilotos permiten un aprendizaje y progresión muy potentes en offroad, no hay nada comparable a estas endurocross miniaturizadas.





KIDS  
SCHOOL











KIDS  
SCHOOL





# PARENTAL CONTROL AND SECURITY

## CONTROL PARENTAL Y SEGURIDAD

### WIRELESS CONTROL

All the Torrot Kids models can be equipped with a wireless controller, which allows parent to remotely limit, configure or even switch off their children's motorcycles from an Android or iOS app.

### CONTROL INALÁMBRICO

Todos los modelos Torrot Kids se pueden equipar con un controlador inalámbrico, que permite a los padres limitar, configurar o incluso desactivar, de forma remota, las motos de sus hijos, mediante una aplicación Android o iOS.

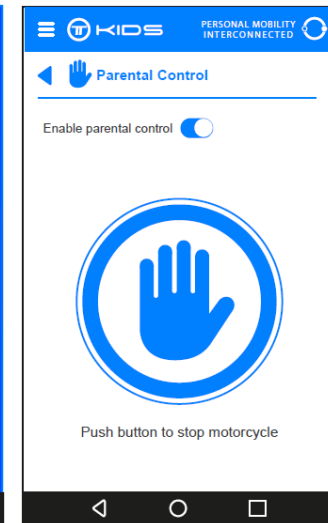
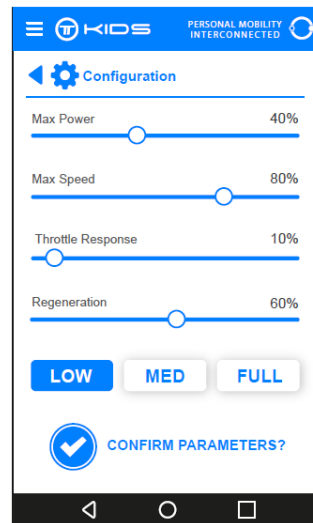

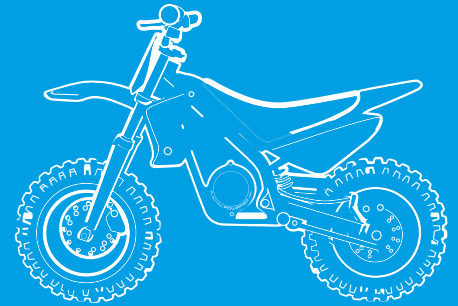



**KIDS**  
T10 E10 S10

# T10 KIDS SERIE 10





- 

KIDS SCHOOL  
KIDS SCHOOL
- 

USB MAPPING  
MAPPING VIA USB
- 

2-YEAR WARRANTY  
GARANTÍA 2 AÑOS
- 

OFF-ROAD ELECTRIC  
OFFROAD ELECTRICA
- 

BRUSHLESS GEARED 48V  
BRUSHLESS GEARED 48V
- 

350 TO 1050W POWERED  
POTENCIA 350 HASTA 1500W
- 

LITHIUM BATTERY  
BATERÍA DE LITIO
- 

DISC BRAKES  
FRENOS DE DISCO
- 

10" 2.50 WHEELS  
RUEDAS 2,50 10"



# TECHNICAL SPECIFICATIONS





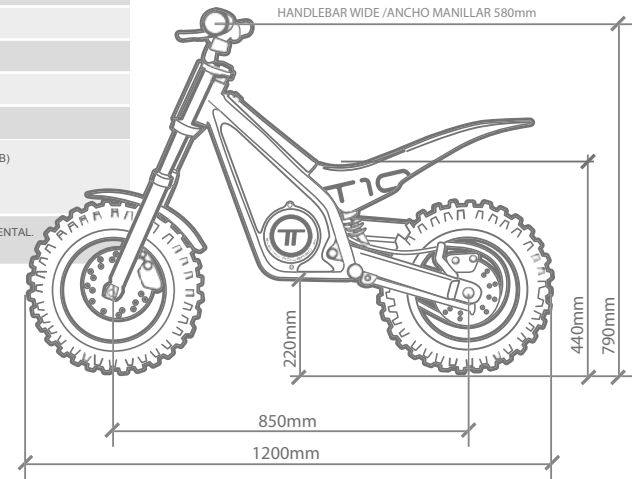



## ESPECIFICACIONES TÉCNICAS

FRAME / CHASIS	TUBULAR CrMo STEEL FRAME / TUBULAR DE ACERO CrMo
FRONT SUSPENSION / SUSP. DELANTERA	EBR FORK (WHEEL TRAVEL 75mm) / HORQUILLA EBR (WHEEL TRAVEL 75mm)
REAR SUSPENSION / SUSP. TRASERA	DNM GAS SHOCK ABSORBER PRELOAD ADJUSTMENT (WHEEL TRAVEL 100mm) / - AMORTIGUADOR GAS DNM. AJUSTE EN PRECARGA (RECORRIDO RUEDA 100mm)
BRAKES / FRENO	HYDRAULIC BRAKE SYSTEM 160mm DISCS FRONT AND REAR / SISTEMA FRENO HIDRAULICO. DISCOS 160mm DEL/TRAS.
MOTOR CONTROLLER / CONTROLADORA MOTOR	48V PROGRAMMABLE TOP SPEED, POWER, THROTTLE SENSITIVITY AND REGENERATION / PROGRAMABLE VELOCIDAD MAX. POTENCIA, TACTO ACELERADOR Y REGENERACIÓN
POWER / POTENCIA	350W-1050W / MÁX SPEED 30KM/H / 350W-1050W / VELOCIDAD MÁX 30KM/H
BATTERY / BATERÍA	48V LINI/CoMn 6,6Ah WITH BMS INTEGRATED (Battery Management System) REMOVABLE / CON BMS INTEGRADO, EXTRAIBLE.
RIMS / LLANTAS	ALUMINUM 10" x 1.60 / ALUMINIO 10" x 1.60
TYRES / NEUMÁTICOS	TORROT TRIAL 2.50-10
WEIGHT / PESO	22KG
MAX PILOT WEIGHT / PESO MÁXIMO PILOTO	30KG
CHARGER / CARGADOR	54.6V 2A BATTERY CHARGER (4 HOURS) / 54.6V 2A CARGADOR DE BATERÍA (4 HORAS)
OTHERS / OTROS	POWER TRAIN MANAGEMENT SOFTWARE INCLUDED. (RS232-USB CABLE REQUIRED) / SOFTWARE CONFIGURACIÓN INCLUIDO (REQUIERE CABLE RS232-USB) INCLUDES POWER SWITCH 50-100% / INCLUYE SWITCH DE POTENCIA 50-100% DESIGNED AND MANUFACTURED IN EUROPE / DISEÑADA Y FABRICADA EN EUROPA
OPTIONAL / OPCIONAL	BLUETOOTH MODULE VIA APP (iOS/Android) REMOTE PARAMETER PROGRAMMING AND PARENTAL CONTROL / PROGRAMACIÓN REMOTA Y CONTROL PARENTAL. TORROT INVERTER FOR CAR CHARGE (LIGHTER SOCKET) / INVERSOR TORROT PARA CARGA EN COCHE (TOMA ENCENDEDOR)



# S10 KIDS SERIE 10



-  KIDS SCHOOL
-  USB MAPPING VIA USB
-  2-YEAR WARRANTY GARANTÍA 2 AÑOS
-  OFF-ROAD ELECTRIC OFFROAD ELÉCTRICA
-  BRUSHLESS GEARED 48V BRUSHLESS GEARED 48V
-  350 TO 1050W POWERED POTENCIA 350 HASTA 1500W
-  LITHIUM BATTERY BATERÍA DE LITIO
-  DISC BRAKES FRENOS DE DISCO
-  10" 2.50 WHEELS RUEDAS 2,50 10"



# TECHNICAL SPECIFICATIONS

## ESPECIFICACIONES TÉCNICAS

FRAME / CHASIS	TUBULAR CrMo STEEL FRAME / TUBULAR DE ACERO CrMo
FRONT SUSPENSION / SUSP. DELANTERA	EBR FORK (WHEEL TRAVEL 75mm) / HORQUILLA EBR (WHEEL TRAVEL 75mm)
REAR SUSPENSION / SUSP. TRASERA	DNM GAS SHOCK ABSORBER PRELOAD ADJUSTMENT (WHEEL TRAVEL 100mm) / - AMORTIGUADOR GAS DNM AJUSTE EN PRECARGA (RECORRIDO RUEDA 100mm)
BRAKES / FRENOS	HYDRAULIC BRAKE SYSTEM 160mm DISCS FRONT AND REAR / SISTEMA FRENO HIDRAULICO. DISCOS 160mm DEL/TRAS.
MOTOR CONTROLLER / CONTROLADORA MOTOR	48V PROGRAMMABLE TOP SPEED, POWER, THROTTLE SENSITIVITY AND REGENERATION / PROGRAMABLE VELOCIDAD MAX. POTENCIA, TACTO ACELERADOR Y REGENERACIÓN
POWER / POTENCIA	350W-1050W / MÁX SPEED 40KM/H / 350W-1050W / VELOCIDAD MÁX 40KM/H
BATTERY / BATERÍA	48V LiNiCoMn 6,6Ah WITH BMS INTEGRATED (Battery Management System) REMOVABLE / CON BMS INTEGRADO, EXTRAIBLE.
RIMS / LLANTAS	ALUMINUM 10" x 1.85 / ALUMINIO 10" x 1.85
TYRES / NEUMÁTICOS	MITAS MC34 90/90-10 50P TL
WEIGHT / PESO	22KG
MAX PILOT WEIGHT / PESO MÁXIMO PILOTO	30KG
CHARGER / CARGADOR	54.6V 2A BATTERY CHARGER (4 HOURS) / 54.6V 2A CARGADOR DE BATERÍA (4 HORAS)
OTHERS/ OTROS	POWER TRAIN MANAGEMENT SOFTWARE INCLUDED. (RS232-USB CABLE REQUIRED) / SOFTWARE CONFIGURACIÓN INCLUIDO (REQUIERE CABLE RS232-USB) INCLUDES POWER SWITCH 50-100% / INCLUYE SWITCH DE POTENCIA 50-100% DESIGNED AND MANUFACTURED IN EUROPE / DISEÑADA Y FABRICADA EN EUROPA
OPTIONAL / OPCIONAL	BLUETOOTH MODULE VIA APP (IOS/Android) REMOTE PARAMETER PROGRAMMING AND PARENTAL CONTROL / PROGRAMACIÓN REMOTA Y CONTROL PARENTAL. TORROT INVERTER FOR CAR CHARGE (LIGHTER SOCKET) / INVERSOR TORROT PARA CARGA EN COCHE (TOMA ENCENDEADOR)

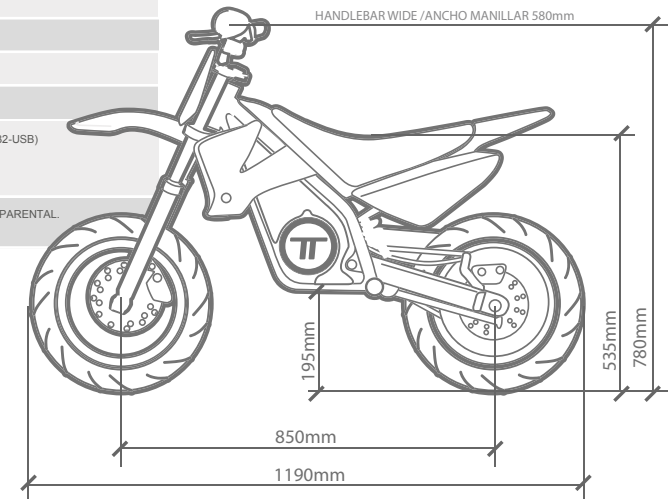



# E10 KIDS SERIE 10



- KIDS SCHOOL  
KIDS SCHOOL
- USB MAPPING  
MAPPING VIA USB
- 2-YEAR WARRANTY  
GARANTÍA 2 AÑOS
- OFF-ROAD ELECTRIC  
OFFROAD ELECTRICA
- BRUSHLESS GEARED 48V  
BRUSHLESS GEARED 48V
- 350 TO 1050W POWERED  
POTENCIA 350 HASTA 1500W
- LITHIUM BATTERY  
BATERÍA DE LITIO
- DISC BRAKES  
FRENOS DE DISCO
- 10" 2.50 WHEELS  
RUEDAS 2,50 10"



# TECHNICAL SPECIFICATIONS

## ESPECIFICACIONES TÉCNICAS

FRAME / CHASIS	TUBULAR CrMo STEEL FRAME / TUBULAR DE ACERO CrMo
FRONT SUSPENSION / SUSP. DELANTERA	EBR FORK (WHEEL TRAVEL 75mm) / HORQUILLA EBR (WHEEL TRAVEL 75mm)
REAR SUSPENSION / SUSP. TRASERA	DNM GAS SHOCK ABSORBER WITH PRELOAD ADJUSTMENT (WHEEL TRAVEL 100mm) / - AMORTIGUADOR GAS DNM AJUSTE EN PRECARGA (RECORRIDO RUEDA 100mm)
BRAKES / FRENO	HYDRAULIC BRAKE SYSTEM 160mm DISCS FRONT AND REAR / SISTEMA FRENO HIDRAULICO. DISCOS 160mm DEL/TRAS.
MOTOR CONTROLLER / CONTROLADORA MOTOR	48V PROGRAMMABLE TOP SPEED, POWER, THROTTLE SENSITIVITY AND REGENERATION / PROGRAMABLE VELOCIDAD MAX, POTENCIA, TACTO ACELERADOR Y REGENERACIÓN
POWER / POTENCIA	350W-1050W / MÁX SPEED 40KM/H / 350W-1050W / VELOCIDAD MÁX 40KM/H
BATTERY / BATERÍA	48V LiNiCoMn 6,6Ah WITH BMS INTEGRATED (Battery Management System) REMOVABLE / CON BMS INTEGRADO, EXTRAIBLE.
RIMS / LLANTAS	ALUMINUM 10" x 1.60 / ALUMINIO 10" x 1.60
TYRES / NEUMÁTICOS	MITAS C-12 2.60-10 TT 37J
WEIGHT / PESO	22KG
MAX PILOT WEIGHT / PESO MÁXIMO PILOTO	30KG
CHARGER / CARGADOR	54.6V 2A BATTERY CHARGER (4 HOURS) / 54.6V 2A CARGADOR DE BATERÍA (4 HORAS)
OTHERS / OTROS	POWER TRAIN MANAGEMENT SOFTWARE INCLUDED. (RS232-USB CABLE REQUIRED) / SOFTWARE CONFIGURACIÓN INCLUIDO (REQUIERE CABLE RS232-USB) INCLUDES POWER SWITCH 50-100% / INCLUYE SWITCH DE POTENCIA 50-100% DESIGNED AND MANUFACTURED IN EUROPE / DISEÑADA Y FABRICADA EN EUROPA
OPTIONAL / OPCIONAL	BLUETOOTH MODULE VIA APP (IOS/Android) REMOTE PARAMETER PROGRAMMING AND PARENTAL CONTROL / PROGRAMACIÓN REMOTA Y CONTROL PARENTAL. TORROT INVERTER FOR CAR CHARGE (LIGHTER SOCKET) / INVERSOR TORROT PARA CARGA EN COCHE (TOMA ENCENDEDOR)

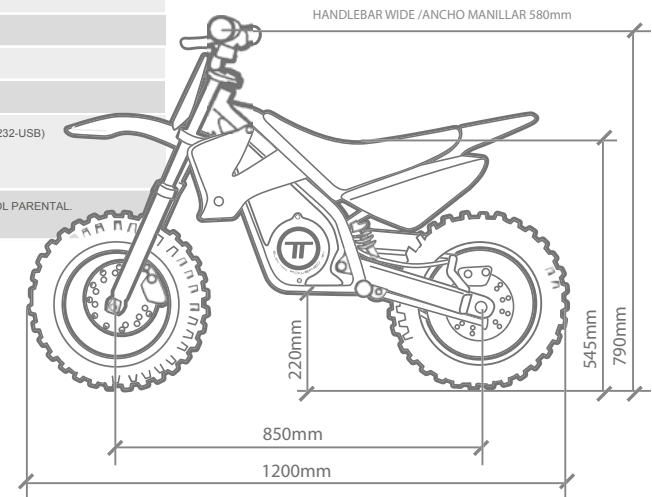



**KIDS  
SCHOOL**

GROWING TOGETHER  
CRECIENDO JUNTOS

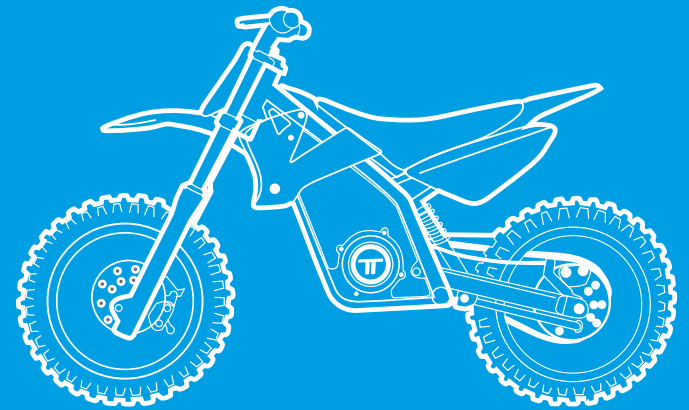



**KIDS**  
S12 E12 T12



# T12 KIDS SERIE 12



- |   |   |   |  |   |   |   |   |
|---|---|---|--|---|---|---|---|
|  |  |  |  |  |  |  |  |
| KIDS SCHOOL   | USB MAPPING   | 2-YEAR WARRANTY   | OFF-ROAD ELECTRIC  | BRUSHLESS GEARED 48V  | 600 TO 1500W POWERED  | LITHIUM BATTERY   | DISC BRAKES   |
| KIDS SCHOOL   | MAPPING VIA USB   | GARANTÍA 2 AÑOS   | OFFROAD ELÉCTRICA  | BRUSHLESS GEARED 48V  | POTENCIA 350 HASTA1500W   | BATERÍA DE LITIO  | FRENOS DE DISCO   |

# TECHNICAL SPECIFICATIONS





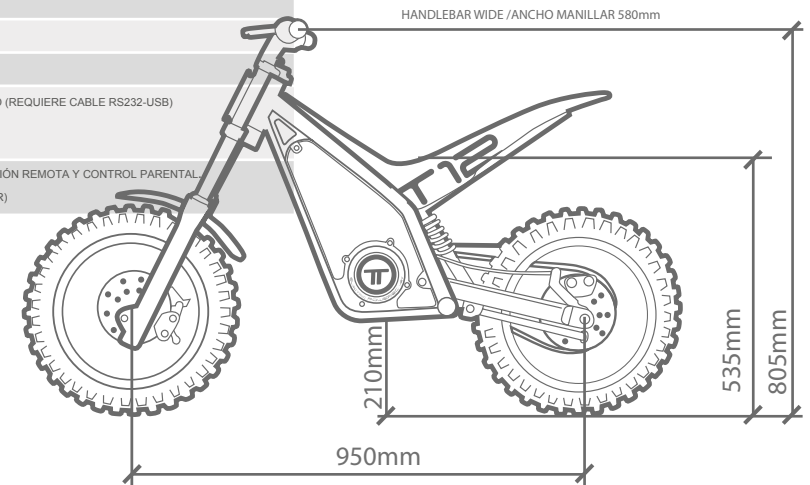



## ESPECIFICACIONES TÉCNICAS

FRAME / CHASIS	TUBULAR CrMo STEEL FRAME / TUBULAR DE ACERO CrMo
FRONT SUSPENSION / SUSP. DELANTERA	EBR HYDRAULIC FORK (WHEEL TRAVEL 100mm) / HORQUILLA HIDRÁULICA EBR (RECORRIDO RUEDA 100mm)
REAR SUSPENSION / SUSP. TRASERA	DNM HYDRAULIC SHOCK ABSORBER PRELOAD ADJUSTMENT (WHEEL TRAVEL 125mm) / AMORTIGUADOR HIDRÁULICO DNM. AJUSTE EN PRECARGA (RECORRIDO RUEDA 125mm)
BRAKES / FRENOS	HYDRAULIC BRAKE SYSTEM (160mm) DISCS FRONT AND REAR / SISTEMA FRENOS HIDRÁULICO. DISCOS (160mm) DEL/TRAS.
MOTOR CONTROLLER / CONTROLADORA MOTOR	48V PROGRAMMABLE TOP SPEED, POWER, THROTTLE SENSITIVITY AND REGENERATION / PROGRAMABLE VELOCIDAD MAX, POTENCIA, TACTO ACELERADOR Y REGENERACIÓN
POWER / POTENCIA	600W-1500W / MÁX SPEED 40KM/H / VELOCIDAD MÁX 40KM/H
BATTERY / BATERÍA	48 V LiNiCoMn 8,8Ah WITH BMS INTEGRATED (Battery Management System) REMOVABLE / CON BMS INTEGRADO, EXTRAIBLE
RIMS / LLANTAS	ALUMINUM 12" x 1.6 / ALUMINIO 12" x 1.6
TYRES / NEUMÁTICOS	TORROT TRIAL 2.50-12
WEIGHT / PESO	30KG
MAX RIDER WEIGHT / PESO MÁXIMO PILOTO	40KG
CHARGER CARGADOR	54.6V 2A BATTERY CHARGER (4 HOURS) / 54.6V 2A CARGADOR DE BATERIA (4 HORAS)
OTHERS/ VARIOS	POWER TRAIN MANAGEMENT SOFTWARE INCLUDED. (RS232-USB CABLE REQUIRED) / SOFTWARE CONFIGURACIÓN INCLUIDO (REQUIERE CABLE RS232-USB) INCLUDES POWER SWITCH 50-100% / INCLUYE SWITCH DE POTENCIA 50-100% DESIGNED AND MANUFACTURED IN EUROPE / DISEÑADA Y FABRICADA EN EUROPA
OPTIONAL / OPCIONAL	BLUETOOTH MODULE VIA APP (IOS/Android) REMOTE PARAMETER PROGRAMMING AND PARENTAL CONTROL / PROGRAMACIÓN REMOTA Y CONTROL PARENTAL TORROT INVERTER FOR CAR CHARGE (LIGHTER SOCKET) / INVERSOR TORROT PARA CARGA EN COCHE (TOMA ENCENDEDOR)



# S12 KIDS SERIE 12



- |   |   |   |  |   |   |   |   |
|---|---|---|--|---|---|---|---|
|  |  |  |  |  |  |  |  |
| KIDS SCHOOL   | USB MAPPING   | 2-YEAR WARRANTY   | OFF-ROAD ELECTRIC  | BRUSHLESS GEARED 48V  | 600 TO 1500W POWERED  | LITHIUM BATTERY   | DISC BRAKES   |
| KIDS SCHOOL   | MAPPING VIA USB   | GARANTÍA 2 AÑOS   | OFFROAD ELÉCTRICA  | BRUSHLESS GEARED 48V  | POTENCIA 350 HASTA1500W   | BATERÍA DE LITIO  | FRENOS DE DISCO   |



# TECHNICAL SPECIFICATIONS





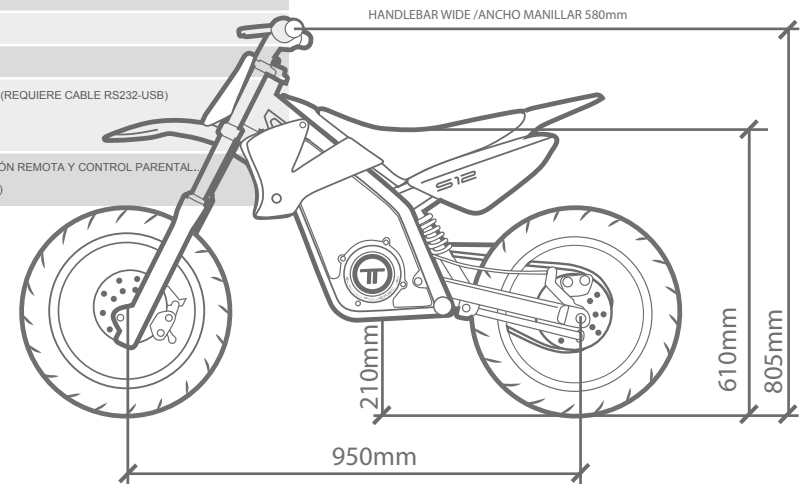



## ESPECIFICACIONES TÉCNICAS

FRAME / CHASIS	TUBULAR CrMo STEEL FRAME / TUBULAR DE ACERO CrMo
FRONT SUSPENSION / SUSP. DELANTERA	EBR HYDRAULIC FORK (WHEEL TRAVEL 100mm) / HORQUILLA HIDRÁULICA EBR (RECORRIDO RUEDA 100mm)
REAR SUSPENSION / SUSP. TRASERA	DNM HYDRAULIC SHOCK ABSORBER PRELOAD ADJUSTMENT (WHEEL TRAVEL 125mm) / AMORTIGUADOR HIDRÁULICO DNM. AJUSTE EN PRECARGA (RECORRIDO RUEDA 125mm)
BRAKES / FRENSOS	HYDRAULIC BRAKE SYSTEM (160mm) DISCS FRONT AND REAR / SISTEMA FRENSOS HIDRÁULICO. DISCOS (160mm) DEL/TRAS.
MOTOR CONTROLLER / CONTROLADORA MOTOR	48V PROGRAMMABLE TOP SPEED, POWER, THROTTLE SENSITIVITY AND REGENERATION / PROGRAMABLE VELOCIDAD MAX, POTENCIA, TACTO ACELERADOR Y REGENERACIÓN
POWER / POTENCIA	600W-1500W / MÁX SPEED 52KM/H / VELOCIDAD MÁX 52KM/H
BATTERY / BATERÍA	48 V LiNiCoMn 8,8Ah WITH BMS INTEGRATED (Battery Management System) REMOVABLE / CON BMS INTEGRADO, EXTRAIBLE
RIMS / LLANTAS	ALUMINUM 12" x 1.85 / ALUMINIO 12" x 1.85
TYRES / NEUMÁTICOS	SUPERMOTARD 90/90-12
WEIGHT / PESO	30KG
MAX RIDER WEIGHT / PESO MÁXIMO PILOTO	40KG
CHARGER CARGADOR	54.6V 2A BATTERY CHARGER (4 HOURS) / 54.6V 2A CARGADOR DE BATERIA (4 HORAS)
OTHERS / VARIOS	POWER TRAIN MANAGEMENT SOFTWARE INCLUDED. (RS232-USB CABLE REQUIRED) / SOFTWARE CONFIGURACIÓN INCLUIDO (REQUIERE CABLE RS232-USB) INCLUDES POWER SWITCH 50-100% / INCLUYE SWITCH DE POTENCIA 50-100% DESIGNED AND MANUFACTURED IN EUROPE / DISEÑADA Y FABRICADA EN EUROPA
OPTIONAL / OPCIONAL	BLUETOOTH MODULE VIA APP (IOS/Android) REMOTE PARAMETER PROGRAMMING AND PARENTAL CONTROL / PROGRAMACIÓN REMOTA Y CONTROL PARENTAL... TORROT INVERTER FOR CAR CHARGE (LIGHTER SOCKET) / INVERSOR TORROT PARA CARGA EN COCHE (TOMA ENCENDEDOR)



# E12 KIDS SERIE 12



- |   |   |   |  |   |   |   |   |
|---|---|---|--|---|---|---|---|
|  |  |  |  |  |  |  |  |
| KIDS SCHOOL   | USB MAPPING   | 2-YEAR WARRANTY   | OFF-ROAD ELECTRIC  | BRUSHLESS GEARED 48V  | 600 TO 1500W POWERED  | LITHIUM BATTERY   | DISC BRAKES   |
| KIDS SCHOOL   | MAPPING VIA USB   | GARANTÍA 2 AÑOS   | OFFROAD ELÉCTRICA  | BRUSHLESS GEARED 48V  | POTENCIA 350 HASTA1500W   | BATERÍA DE LITIO  | FRENOS DE DISCO   |

# TECHNICAL SPECIFICATIONS

## ESPECIFICACIONES TÉCNICAS

FRAME / CHASIS	TUBULAR CrMo STEEL FRAME / TUBULAR DE ACERO CrMo
FRONT SUSPENSION / SUSP. DELANTERA	EBR HYDRAULIC FORK (WHEEL TRAVEL 100mm) / HORQUILLA HIDRÁULICA EBR (RECORRIDO RUEDA 100mm)
REAR SUSPENSION / SUSP. TRASERA	DNM HYDRAULIC SHOCK ABSORBER PRELOAD ADJUSTMENT (WHEEL TRAVEL 125mm) / AMORTIGUADOR HIDRAULICO DNM. AJUSTE EN PRECARGA (RECORRIDO RUEDA 125mm)
BRAKES / FRENOS	HYDRAULIC BRAKE SYSTEM (160mm) DISCS FRONT AND REAR / SISTEMA FRENOS HIDRAULICO. DISCOS (160mm) DEL./TRAS.
MOTOR CONTROLLER / CONTROLADORA MOTOR	48V PROGRAMMABLE TOP SPEED, POWER, THROTTLE SENSITIVITY AND REGENERATION / PROGRAMABLE VELOCIDAD MAX, POTENCIA, TACTO ACELERADOR Y REGENERACIÓN
POWER / POTENCIA	600W-1500W / MÁX SPEED 52KM/H / VELOCIDAD MÁX 52KM/H
BATTERY / BATERÍA	48 V LINiCoMn 8,8Ah WITH BMS INTEGRATED (Battery Management System) REMOVABLE / CON BMS INTEGRADO, EXTRAIBLE
RIMS / LLANTAS	ALUMINUM 12" x 1.6 / ALUMINIO 12" x 1.6
TYRES / NEUMÁTICOS	MITAS C19 2.50-12 TT 37M
WEIGHT / PESO	30KG
MAX RIDER WEIGHT / PESO MÁXIMO PILOTO	40KG
CHARGER CARGADOR	54.6V 2A BATTERY CHARGER (4 HOURS) / 54.6V 2A CARGADOR DE BATERIA (4 HORAS)
OTHERS/ VARIOS	POWER TRAIN MANAGEMENT SOFTWARE INCLUDED. (RS232-USB CABLE REQUIRED) / SOFTWARE CONFIGURACIÓN INCLUIDO (REQUIERE CABLE RS232-USB) INCLUDES POWER SWITCH 50-100% / INCLUYE SWITCH DE POTENCIA 50-100% DESIGNED AND MANUFACTURED IN EUROPE / DISEÑADA Y FABRICADA EN EUROPA
OPTIONAL / OPCIONAL	BLUETOOTH MODULE VIA APP (IOS/Android) REMOTE PARAMETER PROGRAMMING AND PARENTAL CONTROL / PROGRAMACIÓN REMOTA Y CONTROL PARENTAL. TORROT INVERTER FOR CAR CHARGE (LIGHTER SOCKET) / INVERSOR TORROT PARA CARGA EN COCHE (TOMA ENCENDEDOR)

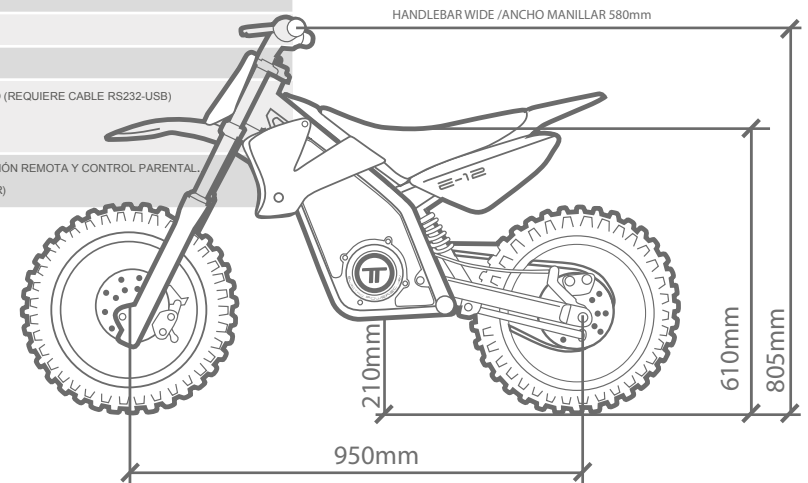

# Legend

 **series**

## FOR YOUNG RIDERS

Motorcycles designed with the collaboration of the greatest legends of motorcycling inspiring children to overcome every day.

## FOR YOUNG RIDERS

Motocicletas diseñadas con la colaboración de las mayores leyendas del motociclismo, inspirando a los niños a superarse día a día.



FONDAZIONE  
**Marco**  
**Simoncelli** **58**

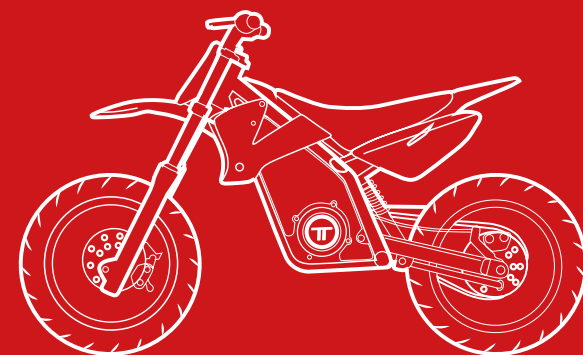

**512** **58**



# S12 58

# Legend

 series



The new LEGEND SERIES S/12 SIC58 named after the famous and appreciated Italian rider MARCO SIMONCELLI! The motorbike is the result of a project carried out in collaboration with "Marco Simoncelli Foundation" and Torrot, who is focused to use its Know-how, to help children to realize their dream to compete, like real pilots on road circuits, offering the maximum safety guaranteed by the Tradition and Experience of the Torrot Electric's Brand.

la nueva Legend serie S / 12 SIC58 lleva el nombre del famoso y querido piloto italiano "Marco Simoncelli". Es el resultado de un proyecto conjunto entre la Fundación Marco Simoncelli y Torrot, enfocada en utilizar su know-how, para ayudar a los más pequeños a realizar el sueño de competir, como verdaderos pilotos, en circuitos off-road u on-road, contando con la máxima seguridad garantizada por la Tradición y la Experiencia de la marca Torrot.

# TECHNICAL SPECIFICATIONS

## ESPECIFICACIONES TÉCNICAS

FRAME / CHASIS	TUBULAR CrMo STEEL FRAME / TUBULAR DE ACERO CrMob
FRONT SUSPENSION / SUSP. DELANTERA	EBR HYDRAULIC FORK (WHEEL TRAVEL 100mm) / HORQUILLA HIDRÁULICA EBR (RECORRIDO RUEDA 100mm)
REAR SUSPENSION / SUSP. TRASERA	DNM HYDRAULIC SHOCK ABSORBER PRELOAD ADJUSTMENT (WHEEL TRAVEL 125mm) / AMORTIGUADOR HIDRAULICO DNM. AJUSTE EN PRECARGA (RECORRIDO RUEDA 125mm)
BRAKES / FRENOS	HYDRAULIC BRAKE SYSTEM (160mm) DISCS FRONT AND REAR / SISTEMA FRENOS HIDRAULICO. DISCOS (160mm) DEL./TRAS.
MOTOR CONTROLLER / CONTROLADORA MOTOR	48V PROGRAMMABLE TOP SPEED, POWER, THROTTLE SENSITIVITY AND REGENERATION / PROGRAMABLE VELOCIDAD MAX, POTENCIA, TACTO ACELERADOR Y REGENERACIÓN
POWER / POTENCIA	600W-1500W / MÁX SPEED 52KM/H / VELOCIDAD MÁX 52KM/H
BATTERY / BATERÍA	48 V LiNiCoMn 8,8Ah WITH BMS INTEGRATED (Battery Management System) REMOVABLE / CON BMS INTEGRADO, EXTRAIBLE
RIMS / LLANTAS	ALUMINUM 12" x 1.85 / ALUMINIO 12" x 1.85
TYRES / NEUMÁTICOS	SUPERMOTARD 90/90-12
WEIGHT / PESO	30KG
MAX RIDER WEIGHT / PESO MÁXIMO PILOTO	40KG
COLOR & TRIM	SIC58 COLOURS - NUMBERED 1 TO 158 ALUMINIUM PLATE / COLORES SIC 58 - PLACA DE ALUMINIO SERIE 1 A 158
CHARGER CARGADOR	54.6V 2A BATTERY CHARGER (4 HOURS) / 54.6V 2A CARGADOR DE BATERIA (4 HORAS)
OTHERS/ VARIOS	POWER TRAIN MANAGEMENT SOFTWARE INCLUDED. (RS232-USB CABLE REQUIRED) / SOFTWARE CONFIGURACIÓN INCLUIDO (REQUIERE CABLE RS232-USB) INCLUDES POWER SWITCH 50-100% / INCLUYE SWITCH DE POTENCIA 50-100% DESIGNED AND MANUFACTURED IN EUROPE / DISEÑADA Y FABRICADA EN EUROPA
OPTIONAL / OPCIONAL	BLUETOOTH MODULE VIA APP (IOS/Android) REMOTE PARAMETER PROGRAMMING AND PARENTAL CONTROL / PROGRAMACIÓN REMOTA Y CONTROL PARENTAL... TORROT INVERTER FOR CAR CHARGE (LIGHTER SOCKET) / INVERSOR TORROT PARA CARGA EN COCHE (TOMA ENCENDEDOR)



HANDLEBAR WIDE / ANCHO MANILLAR 580mm

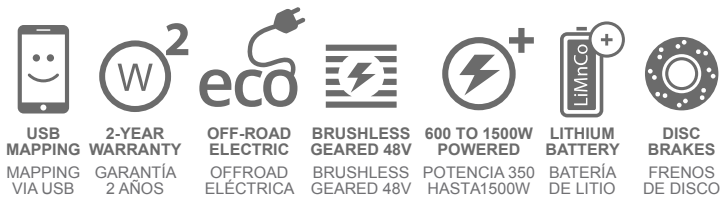
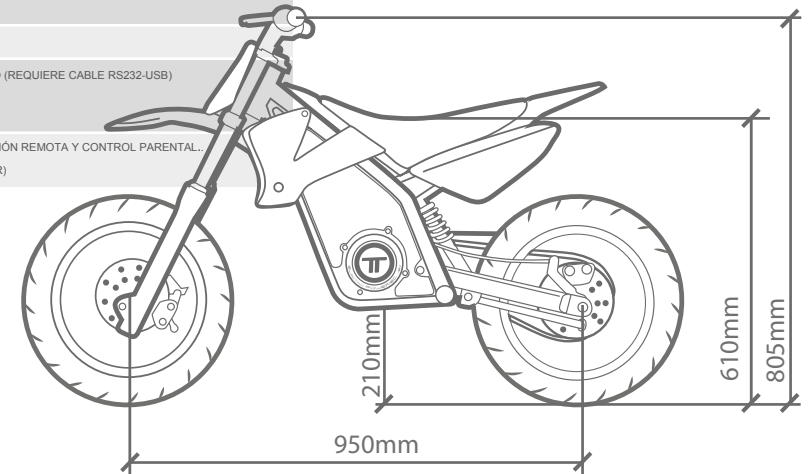

MAPPING VIA USB  
GARANTÍA 2 AÑOS

OFFROAD ELÉCTRICA

BRUSHLESS GEARED 48V

POTENCIA 350 HASTA 1500W

BATERÍA DE LITIO

FRENOS DE DISCO



 **TORROT**  
(0034) 972 850 797

 [info@torrot.com](mailto:info@torrot.com)

 [torrotelectric](https://www.facebook.com/torrotelectric)

 [@torrotelectric](https://twitter.com/torrotelectric)



TORROT ELECTRIC EUROPA S.L.  
Polígono Industrial Vallveric - Remences 44  
08304 Mataró-BARCELONA